

# VIRUS SW - 80



## ***AIRPLANE SYSTEMS*** ***&*** ***STANDARD OPERATING PROCEDURES***

*“When once you have tasted flight, you will forever walk the earth with your eyes turned skyward, for there you have been, and there you will always long to return.”*

- Leonardo Da Vinci

*Flying is the second greatest thrill known to man. Landing is the first.*

*The exhilaration of flying is too keen, the pleasure too great, for it to be neglected for long”*

- Orville Wright

*“It is possible to fly without motors, but not without knowledge and skill”*

- Wilbur wright

*“Flying – more than anything else the sensation of perfect peace, mingled with an excitement that strains every nerve to the utmost, if one can conceive of such a combination”*

- Wright Brothers

## INDEX

1. AIRPLANE SYSTEMS DESCRIPTION
2. LIMITATIONS / PROHIBITIONS / RESTRICTIONS
3. TECHNICAL SPECIFICATIONS
4. NORMAL OPERATING PROCEDURES
5. CIRCUIT APPROACH & LANDING
6. STALL & SPIN RECOVERY
7. EMERGENCY PROCEDURES

# CHAPTER I

## AIRPLANE SYSTEM DESCRIPTION

### INTRODUCTION

1. *Virus SW – 80 (Short Wing with 80 HP Power Plant “Garud” microlite aircraft is a high wing, 3 axes control, two seater, T – tail aircraft, primarily made of composite material. It is powered by a single ROTAX 912 A, 4 cylinder horizontally opposed 4 stroke engine. The undercarriage is a robust tri cycle type with two main, brake equipped wheels, mounted on a U-piece composite strut and a steerable nose wheel. The aircraft is manufactured by Pipestral, Slovenia, European Union. It is a highly advanced, high performance microlite aircraft equipped with state of art navigational aids and avionics equipment. The aircraft features flaperons, one movable surface on each wing that acts as both flap and aileron. Full dual main flight control levers make Virus SW 80, ideal for initial as well as for advanced flight training. The aircraft ships with H type safety belts attached to the fuselage at three mounting points. Seats feature a removable seat cushion that elevates the seat position for better visibility.*



## AIRFRAME SYSTEMS

2. Aircraft Construction. Virus SW 80 is a 10.5 m wing span, two seat, T Tail, high wing plane made almost entirely of composite materials. All composite parts are made of glass, carbon foam, fabric, Kevlar and acrylic paint. Composite parts are made in moulds, hence no structural or shape differences exist. Firewall is reinforced by heat and noise insulation using glass-flame retardant sandwich. Metal parts used in the aircraft include tubes, sheet metal, rods, cable bolts and nuts.

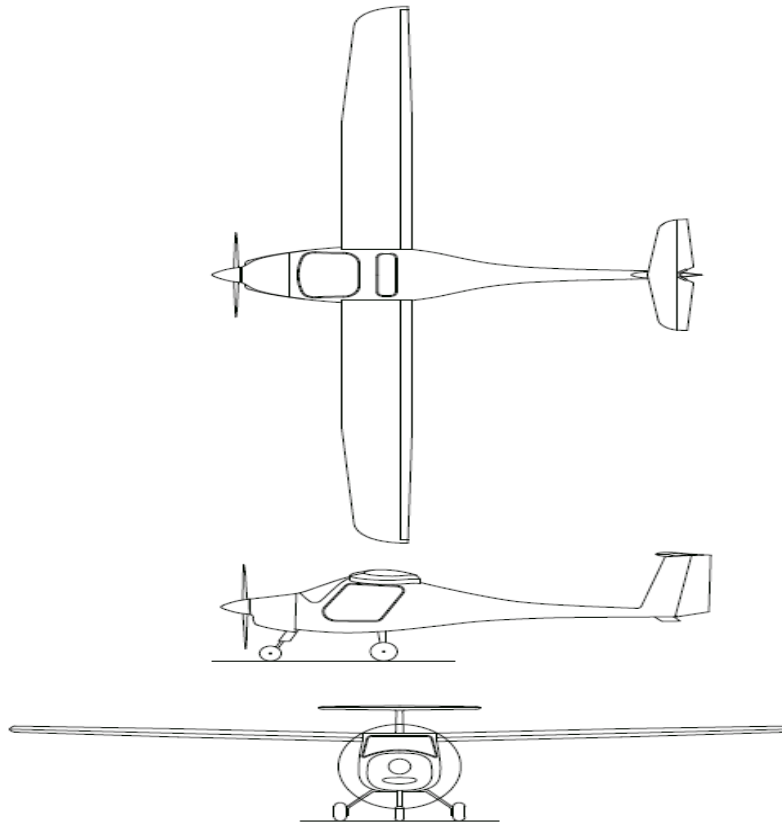

3. Cockpit. Cockpit windshields, doors and overhead windows are transparent surfaces, made of 2mm anti UV GE tinted Lexan, specially developed so as not to shatter or split on impact. Cabin ventilation is achieved through special vents provided on doors. Provision for cabin heating and windshield defrost / demist is provided for, by utilizing hot air

from the engine. The cabin accommodates two fixed seats with 'H' type safety harness on three mounting points. The seats also feature removable seat cushions to elevate seating height, while leg length adjustment is provided for, on rudder pedals.

4. All engine & flight control operating levers are located in the cabin. Cockpit also accommodates a wheel brake lever that controls main undercarriage brakes hydraulically. Elevator trim is electrical, driving a spring mechanism through a common switch, to reduce stick loads. A parachute and rocket system is installed behind right seat for emergency rescue and its activation handle is located overhead between both pilots.

5. Undercarriage. Undercarriage is a robust tricycle type with two main, brake equipped wheels, on each side and a nose wheel. The main undercarriage is a fixed type, 'U'-piece composite strut, equipped with disc type brakes, that are hydraulically operated. Nose undercarriage has a spring type shock absorber and a steerable nose wheel. The nose wheel, connected by cables, is steered through rudder pedals. All wheel tyres are tube type. Wheel brakes are disc type, hydraulically operated, actuated together by pulling on the common handbrake lever located on the central column in cockpit. Parking brake function is achieved by using a lock latch on the handbrake lever. Braking function is not available on the nose wheel.

6. Flight Control System. Virus SW 80 features flaperons, elevators and rudder as flying control surfaces. Full dual main flight control levers make the airplane ideal for basic and advanced flight training. Flight controls viz., flaps, ailerons and elevators are connected to cabin controls using self fitting push pull tubes. Rudder is controlled via cables connected to pedals. Elevator trim is electro-mechanical, driving a spring mechanism, with a common cockpit switch available to both pilots. Flaperons are installed at the trailing edge of each wing. Two different control levels are used for flaps and ailerons. Lateral movement of the dual flight control stick effects the aileron movement of the flaperon, while a flap lever located

between both seats is used for facilitating movement of flaps. The flaps offer 3 position settings viz., Position 0 (Bottom most) for fully retracted, Position 1 (middle) for 15 degrees extended and Position 2 (top) for 25 degrees extended.

7. Parachute Rescue System. GRS rocket charged Parachute Rescue System is installed behind the right seat for emergency rescue. The system is placed inside a durable cylinder mounted on right hand side of baggage compartment. Parachute is placed inside a deployment bag inside the cylinder, with a rocket engine underneath. The PRS is activated manually by pulling the activation handle, mounted on the back wall, between both pilots. After pulling the activation handle, the main canopy opens in 3.2 seconds. The handle is secured with a safety pin.

8. Fire Extinguisher. Fire extinguisher is a poly foam AFFF (Aqueous Film Forming Foam) compound for extinction of hydrocarbon and polar solvent fires. It contains fluorinated and hydrocarbon surfactants in order to allow formation of an aqueous film on the surface of most hydrocarbon fuels, reducing vapour leaks and preventing contact with oxygen.

Note : AFFF is a synthetic foam that has low viscosity and spreads rapidly across the surface of most hydro carbon fuels. A water film forms beneath the foam, which cools the liquid fuel, stopping the formation of flammable vapours.

9. Propeller. Propeller is a two blade fixed pitch design, with propeller diameter of 1650mm. Propeller drive is achieved from the central cam shaft through an integrated reduction gear box with integrated mechanical shock absorber and overload clutch. The gear box provides a reduction ratio of 1 : 2.27.

## POWER PLANT



10. The aircraft is powered by Rotax 912 A (80 HP) four stroke, four cylinder, horizontally opposed, twin carbureted, spark ignition (dual electronic), single central cam shaft engine. It is equipped with a dry sump cooling system and is lubricated centrally with own oil pump. The power plant features Ram Air Cooled Cylinders, Liquid (Water) Cooled Cylinder Heads and Oil Cooled moving parts. Cooling air intakes are located left and right on the bottom part of the engine cover. Engine itself does not feature a cooling fan and is dependent on moving air or air speed. While running, engine oil is cooled by being passed through a radiator. The engine is equipped with Dry Sump Forced Lubrication, Dual Breakerless Capacitor Discharge Ignition (CDI), two Constant Depression Carburetors, a Mechanical Fuel Pump, Electric Starter, Integrated AC Generator with External Rectifier Regulator and Propeller Drive via gear box with Integrated Mechanical Shock Absorber and Overload Clutch.

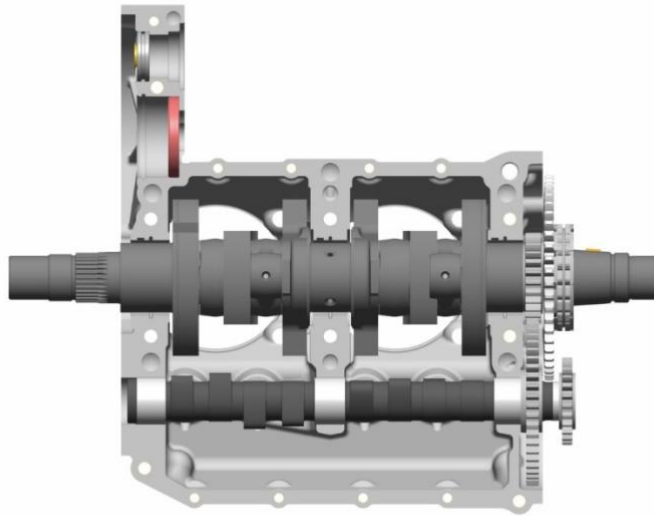

**CRANKCASE ASSEMBLY WITH CRANKSHAFT & CAMSHAFT**

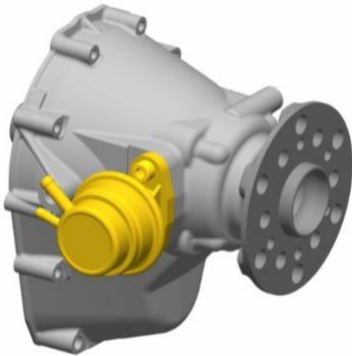

**GEARBOX WITH MECHANICAL FUEL PUMP**

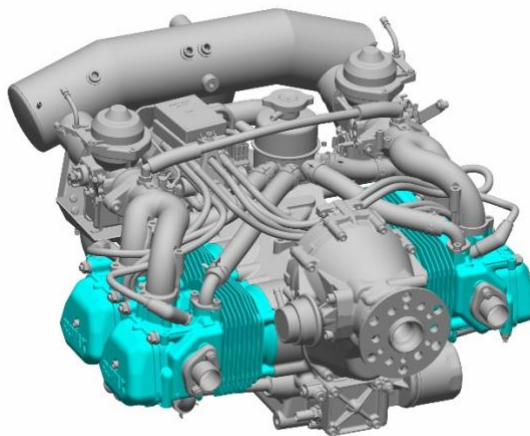

**CYLINDER SECTION**

11. Fuel System. Fuel system comprises a vented fuselage fuel tank refueling aperture on top left side of the fuselage behind the wing. Fuel tank is located inside the fuselage with a fuel shutoff valve inside the cockpit. Fuel hoses are protected with glass and silicon rubber and fuel system features fuel return circuit into the fuel tank. The system has an electric gauge style fuel quantity indication, built into the quadrant display (EMS). Principle of indication is via float with position detection inside the fuel tank. Rate of fuel flow is calculated from RPM and MAP (Manifold Pressure) measurements. Draining of water / particles is achieved through draining contents of gascolator, located below the bottom engine cowling.

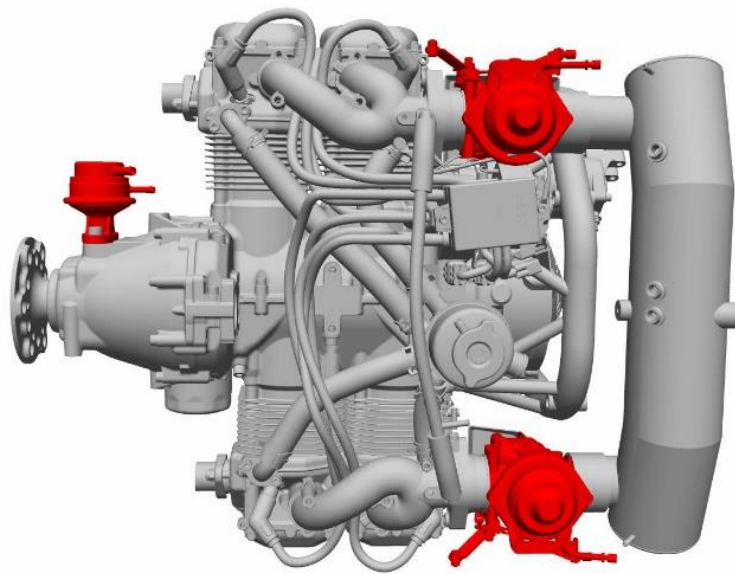

**Fuel System**

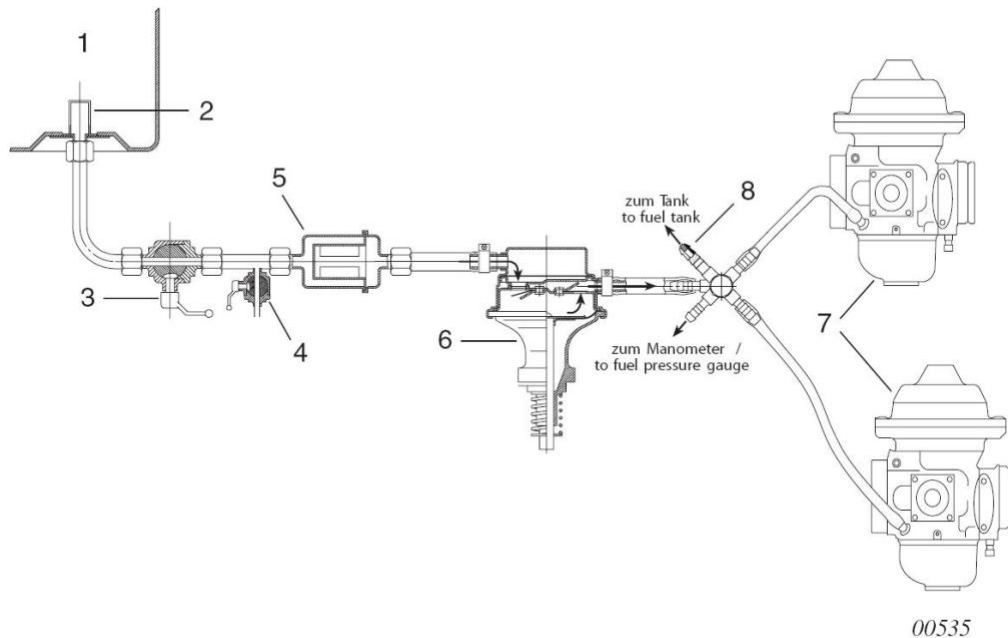

- ▶ *The fuel flows from the tank (1) via a coarse filter (2) the safety cock (3), water drain cock (4) and fine filter (5) to the mechanical fuel pump (6). From the pump fuel passes on to the two carburetors. (7).*
- ▶ *Optional electric fuel pump is usually fitted between fine filter (5) and mechanical fuel pump (6)*

12. Cooling System. Cooling system is designed for liquid cooling of cylinder heads and ram air cooling of cylinders. Coolant flow for cooling cylinder heads is forced by a engine / cam shaft driven water pump, from radiator to cylinder heads. Engine does not comprise of a cooling fan, hence cooling of engine is entirely dependent on ram / moving air and air speed.

13. Lubrication System. Engine is lubricated by dry sump forced lubrication. Engine cam shaft driven oil pump sucks engine oil from the oil tank and forces it through oil filter to individual lubrication points. Surplus oil from lubrication points accumulates at the bottom of crank case and is forced back to oil tank by blow by gases. Hot oil after lubricating the engine is cooled by passing through a radiator.

## Electrical System

14. Electrical system is characterized by separate magneto toggle switches, switch type Master switch and an avionics switch. Individual fused rocker switches are used to control individual electric loads, apart from avionics. Lighting provides for wing tip navigation lights and strobe lights. Internal gooseneck cockpit lighting is available in addition to backlit instruments with day / night visible displays.

15. Battery is light weight (1.62 Kg) and based on Lithium Phosphate principle. It is a dry battery (no liquid) with lithium iron phosphate for maximum safety, in ABS (Acrylonitrile Butadiene Styrene) plastic housing. It is electromagnetic compatible and has a integrated electronic overload control and Battery Management System (BMS) balance. It is capable of operation within a temperature range of – 30 deg Celsius to + 60 deg Celcius, with a maximum operating altitude of 5000 metres.

16. Electrical system comprises a 12 Volt circuit provided by engine driven electric alternator and a 12 Volt 10 AH (Ampere-Hour) battery. Alternator provides a power output of 250 Watt at maximum engine RPM. The AC (Alternating Current) from the alternator is provided to a 12 Volt Busbar through a Regulator Rectifier, that caters for all electric loads, as also for charging the battery. Other loads supplied by the electrical system include, electric Fuel Boost pump supplied through Master switch and Fuel CB, electric starter, external & internal lighting, instruments, communication system, Engine Management Systems Quadrant Display, Navigation GPS (Global Positioning System) – Garmin Aero 500.

## Instrument Panel.

17. Instrument panel consists analogue (altitude, slip & trim) indicators, digital (GPS / engine instrument cluster / radio) indicators and hybrid (analogue & digital) airspeed, tachometer and variometer gauges. Electrical

panel consists of starter button, fuel pump CB, 12 Volt socket, Fail light rocker switches (Master, Avionics & magnetos), battery disconnect ring and cabin light lever. Battery disconnect mechanically disables the complete electrical system.

### Instrument / Communication / Navigation Systems.

18. Instrument System is fitted with Digital / Analogue gauges for airspeed, altitude, RPM, vertical speed indications. Additional engine parameters (Manifold Pressure, Exhaust Gas Temperature – EGT, Coolant Temperature, Oil temperature, Oil pressure, Fuel Quantity, Fuel Pressure, Busbar & Battery Voltage, Fuel Flow) are displayed on Right Hand Quadrant Display (Engine Cluster) system.

19. Communication & Navigation System includes a modern light weight radio unit (X COM VHF 760 Transreceiver) and Garmin Aera 500 GPS touch screen Navigation system.

(a) Altimeter. Altitude is indicated in feet. Altimeter has two indicators on LCD display. Indications include

- (i) Flight Level
- (ii) Altitude referenced / 1013.25 HPa
- (iii) QNH in HPa
- (iv) Altitude in feet

(b) Air Speed Indicator. ASI indicates speed in Knots, both on digital and analogue display. The speed indication turns red when speed exceeds 135 Kts and starts to pulse / blink when speed drops below 40 Kts.

(c) Tachometer. Range of Tachometer is 0 – 7000 RPM displayed both on analogue and digital LCD. The instrument displays

engine RPM and Engine Hour Totaliser (Progressive Hours Run). RPM display turns red when engine RPM is above 5800. Totaliser starts counting engine hours when RPM exceeds 700.

(d) Variometer. Variometer combines indication of vertical speed in both meters per second and feet per minute on analogue display and only in feet per minute on digital LCD. Additional LCD is provided to indicate flight time which starts registering when speed exceeds 36 Kts for more than 05 seconds.

20. Engine Cluster Display.

(a) Oil Pressure. Displayed in PSI, if oil pressure value drops below 14.5 PSI, displayed value becomes red with 'LOW' warning. If oil pressure rises above 94.3 PSI, displayed value becomes red with 'HIGH' warning.

(b) Oil Temperature. Displayed in deg Celsius. If oil temperature rises above 125 deg Celsius, displayed value becomes red with 'HIGH' warning. No alarm / warning exists for low oil temperature. Warning message is also displayed when engine is turned off.

(c) Coolant Temperature (CT1 & CT2). Coolant temperature is displayed in deg Celsius. If coolant temperature rises above 120 deg Celsius, displayed value becomes red with 'HIGH' warning.

(d) Manifold Pressure (MAP). Displayed in millimeter of Hg, with out warning.

(e) Main Bus Voltage (Volt Bus) & Battery Voltage (Batt Volt). Voltage is displayed in volts. If voltage drops below 11.4 volts, displayed Busbar voltage value becomes red with 'LOW' warning. If

voltage value rises above 14.4 Volts, displayed value becomes red with 'HIGH' warning. Warning message is also displayed when engine is OFF.

(f) Fuel Pressure. Displayed in PSI. If value drops below 2.2 PSI, it turns red with 'LOW' warning. If fuel pressure rises above 5.8 PSI, displayed value becomes red alternatively with 'HIGH' warning.

(g) Exhaust Gas Temperature (EGT 1 & EGT 2). Displayed in deg Celsius. If EGT rises above 925 deg Celsius, displayed value becomes red with 'HIGH' warning. No alarm is provided for low EGT. Warning is also displayed when engine is OFF.

(h) Fuel Quantity. Displayed in percentage. If fuel quantity drops below 10 ltrs, displayed value becomes red with 'LOW' warning.

(j) Fuel Flow. Displayed in ltrs per hour. Value is calculated is dependent on values of engine RPM, Manifold pressure and engine fuel consumption data. Display available only when more than 10 ltr fuel is available in tank.

21. Communication System. X COM VHF 760 Transreceiver has digital volume control, squelch control, VOX intercom control on front panel. It has 99 memory channels of which one is for primary channel of VHF Guard Frequency (121.5 MHz). It also provides for 88 user defined channels. The display also provides for low battery alert for under voltage (< 10.5 Volts DC) and over voltage (> 14.5 Volts DC).

22. Navigation System. Garmin AERA 500 GPS is an easy to use, 4.3 inch touch screen (Colour) TFT display with white backlight. Equipped with a lithium ion battery that lasts upto 5 hours, depending on usage & settings, it has a fast 5 Hz GPS refresh rate. It has a map display with terrain and obstacle warnings. Flight plan mode comprises of 50 – 300 way points and

*can log at least 30 most recent flights. A rugged and water proof unit, the system automatically adjusts time zones while navigating with a high sensitivity receiver for position accuracy through improved performance and reception.*

*23. Pitot Static System. Pitot tube is attached to bottom side of right hand wing. Pitot lines lead through inside of the wing all the way to the instrument panel.*

## CHAPTER II

### LIMITATIONS / PROHIBITIONS / RESTRICTIONS

#### 24. MANUEVRE LIMITATIONS.

- (a) *Power on / off stalls are not to be carried out below 1500 ft AGL.*
- (b) *Power on / off lazy eights are not to be carried out below 1500 ft AGL, with entry speed 110 Kts.*
- (c) *Steep turns are to be carried out with initial speed of 100 Kts.*
- (d) *Chandelle manoeuvres with an entry speed of 120 Kts, are not to be carried out below 500 feet AGL.*
- (e) *Spin initiation is not to be carried out below 2500 ft AGL and recovery to be initiated at maximum 180 deg in actual spinning manoeuvre.*
- (f) *Aircraft approved for Day VFR operations only.*

#### 25. Prohibitions.      *The following is prohibited.*

- (a) *Flying with both doors open.*
- (b) *Flying in heavy rainfall.*
- (c) *Flying in thunderstorm activity / known icing conditions.*
- (d) *Flying in blizzards.*
- (e) *Flying in IMC / IFR conditions.*

- (f) *Flying when OAT above 55 deg celsius.*
- (g) *Flying when fuel used with more than 10 % alcohol.*
- (h) *Aerobatic manuevres including full developed spin.*
- (j) *Take off & Landing with flaps fully retracted.*

26. Limitations / Restrictions / Warnings.

- (a) *Maximum wind speed for parking outdoors without tie down is 15 Kts.*
- (b) *Maximum wind speed for parking outdoors with tie down is 40 Kts.*
- (c) *Flying in side slip turbulence may result in non precise fuel quantity indication.*
- (d) *Soft grass runways (unpaved) tend to increase take off performance data by 20 %.*
- (e) *Headwinds shorten take off and landing length required by 8 mtrs for every 3 Kts / 5 Kmph of increase in wind speed.*
- (f) *Tailwinds extend take off and landing length required by 18 – 28 mtrs for every 3 Kts / 5 Kmph of increase in wind speed.*
- (g) *Tailwinds affect take off and landing performance by more than twice, as much as headwind does.*

## CHAPTER III

### TECHNICAL SPECIFICATIONS

#### AIRFRAME

<i>Wing Span</i>	-	10.5 metres
<i>Length</i>	-	6.5 metres
<i>Height</i>	-	2.05 metres
<i>Wing surface area</i>	-	9.29 Sq metres
<i>Vertical Fin Area</i>	-	1.10 Sq metres
<i>Horizontal Stabilizer and</i>	-	1.08 Sq metres
<i>Vertical fin area</i>		
<i>Aspect Ratio</i>	-	11.8
<i>Positive Flaps Down</i>		
<i>Position 1</i>	-	15 deg
<i>Position 2</i>	-	25 deg
<i>Centre of Gravity limits</i>	-	20% - 38% of MAC
		220mm – 368mm backwards of datum
<i>Max T/O weight (MTOW)</i>	-	472.5 Kgs
<i>Max Ldg weight (MLW)</i>	-	472.5 Kgs
<i>Standard empty weight</i>	-	275 Kgs
<i>Max useful load</i>	-	197.5 Kgs
<i>Max baggage weight</i>	-	20 Kgs

*Max load per seat* - 110 Kgs  
*Min combined crew weight* - 55 Kgs

*Fuel capacity Total* - 50 Ltrs  
*Fuel capacity usable* - 48 Ltrs  
*Oil capacity* - 03 Ltrs

*'G' Load Factors*

*Max +ve 'G'* - + 4 G  
*Max -ve 'G'* - - 2 G  
*Tested min safety factor* - 1.875

*ENGINE / POWERPLANT*

*Engine Type* - *Rotax 912 A (80 HP)*  
*4 Stroke 4 Cylinder*  
*Horizontally Opposed*  
*Spark Ignition*

*Propeller* - *FP 02 – 80 Fixed Pitch*

*Propeller diameter* - *1650 mm*

*Absolute ceiling at MTOW* - *6200 metres / 20,300 feet*

*Engine Performance* - *58.0 KW (79 HP) at 5500 RPM*  
*59.6 KW (81 HP) at 5800 RPM*  
*(Maximum 05 minutes)*

<i>Torque</i>	-	<i>103 Nm (75.9 foot pounds) at 4800 RPM</i>
<i>Max permitted RPM</i>	-	<i>5800 (Max 05 minutes)</i>
<i>Compression Ratio</i>	-	<i>9 : 1</i>
<i>Cooling System</i>	-	<i>Water cooled Cylinder Heads Ram Air cooled Cylinders</i>
<i>Lubrication System</i>	-	<i>Dry Sump Forced Lubrication</i>
<i>Ignition System</i>	-	<i>Dual Breakerless Capacitor Discharge</i>
<i>Max coolant temperature</i>	-	<i>120 deg C</i>
<i>EGT Normal</i>	-	<i>650 deg C – 885 deg C</i>
<i>Max EGT</i>	-	<i>900 deg C</i>
<i>Max EGT difference</i>	-	<i>30 deg C</i>
<i>Oil Temperature Min</i>	-	<i>50 deg C</i>
<i>Normal</i>	-	<i>90 deg C – 110 deg C</i>
<i>Max</i>	-	<i>140 deg C</i>
<i>Oil Pressure Min</i>	-	<i>1.0 Bar (14.5 PSI)</i>
<i>Max</i>	-	<i>6.0 Bar (87.0 PSI)</i>
<i>Engine RPM Max</i>	-	<i>5500 (on ground)</i>

*Max Permitted RPM - 5800 (Max 05 minutes)*

*Magneto Drop Check at - 4000 RPM*

*Single magneto drop Max - 300*

*Max difference in magneto - 115*

*Drop*

*Fuel Recommended - Unleaded Super Grade 87 or above  
Max 10 % alcohol*

28. Performance.

Take Off Performance

*T/O Ground roll at MTOW - 140 metres*

*T/O Ground roll - 225 metres*

*(over 50 ft obstacle)*

Note. *Depends on wind / temperature, elevation, wing & propeller surface condition.*

Climb Performance

*Best Climb Speed - 76 Knots*

*Best Climb Rate at MTOW - 1220 feet per minute (6.1 m/sec)  
(at Sea Level)*

*Best Climb rate at 100 Kts - 800 feet per minute (4.0 m/sec)*

### Cruise Performance

*Cruise Air Speed* - 112 Kts

### Descent Performance

*Sink Rate at 50 Kts* - 440 feet per minute (2.2 m/sec)  
(full flaps – Power Idle)

### Glide Performance

*Minimum Sink Rate Speed* - 58 Knots  
*Minimum Sink Rate Flaps 15°* - 460 feet per minute (2.3 m/sec)  
*Best L/D ratio speed* - 64 Knots  
*Best L/D ratio Flaps 15°* - 17 : 1

### Landing Performance

*Final Approach Speed* - 50 Knots with Flaps 25°  
*Landing roll at MTOW (SL)* - 410 feet

## 29. Airspeeds.

*Stall Speed Vs (Clean / Flaps Up)* - 43 Knots  
*Stall Speed Vso (Flaps 25°)* - 35 Knots  
(Landing Configuration)  
*Max Speed V FE 15 (Flaps 15°)* - 70 Knots

<i>Max Speed V FE 25 (Flaps 25°)</i>	-	55	Knots
<i>Max Design maneuvering speed V<sub>A</sub></i>	-	86	Knots
<i>Max Speed V<sub>NE</sub></i>	-	135	Knots
<i>Normal Operating Speed V<sub>NO</sub></i>	-	108	Knots

30. ASI Markings.

<i>White Band</i>	-	35 – 70	Knots
		65 – 130	Kmph

- \* - *Full Flap Operating Range*
- *Lower limit is maximum weight V<sub>so</sub>*
- *Upper limit is maximum speed with Flaps 1 (15°) Position*

<i>Green Band</i>	-	43 – 108	Knots
		83 – 201	Kmph

- \* - *Normal Operating Range*
- *Lower limit is maximum weight V<sub>s1</sub> at C of G max forward & Flaps fully retracted*
- *Upper limit is maximum structural cruising speed (in turbulent air)*

<i>Yellow Band</i>	-	108 – 135	Knots
--------------------	---	-----------	-------

- \* - *Manoeuvre speed (with caution) in calm air only*

<i>Red Band</i>	-	135	Knots
-----------------	---	-----	-------

\* - *Maximum speed for all operations (V<sub>NE</sub>)*

31. Engine Instrument Markings.

Tachometer / RPM

<i>Minimum RPM (Red Line)</i>	-	1600
<i>Normal Operating (Green)</i>	-	1600 – 5500
<i>Caution Range (Yellow)</i>	-	5500 – 5800
<i>Max RPM (Red Line)</i>	-	5800

Oil Temperature

<i>Minimum Temperature (Red)</i>	-	50° C
<i>Normal Range (Green)</i>	-	90° C – 110 ° C
<i>Caution Range (Yellow)</i>	-	110° C – 140° C
<i>Maximum Temperature (Red)</i>	-	140° C

Coolant Temperature (CT)

<i>Caution Range (Yellow)</i>	-	110° C - 120° C
<i>Maximum Temperature (Red)</i>	-	120° C

Oil Pressure

<i>Minimum Pressure (Red)</i>	-	1 Bar (14.5 PSI)
-------------------------------	---	------------------

*Maximum Pressure* - *6 Bar (87.0 PSI)*

*Electrical System*

*Battery* - *Lithium Phosphate, 12 Volts*  
*Nominal 7.5 Amp Hour*

*Alternator* - *12 Volts, 250 W at 5500 RPM*  
- *Provides dual electronic ignition*  
- *Charges battery*  
- *Provides power to all appliances /*  
*Instruments*  
- *Provides supply to Nav / Strobe*  
*Lights, Cockpit Lights, Radio, GPS,*  
*Instruments*

## CHAPTER IV

### NORMAL OPERATING PROCEDURES

#### CHECKS & PROCEDURES

1. *Before proceeding to aircraft, ensure the following.*
  - (a) *Pre flight briefing carried out, covering the complete sortie profile.*
  - (b) *Pre flight meals / medical completed. All participants are fully fit to fly.*
  - (c) *Authorisation Book filled in and signed.*
  - (d) *Form – 700 completed in all respects and closed / signed.*
2. *After completion of the above actions proceed to the aircraft.*
3. Cockpit Preflight Inspection.
  - *Inside cockpit, check instruments and instrument panel for condition*
  - *Check battery disconnection ring in slot*
  - *All switches off*
  - *Select Master Switch ON, check Gene Fail light ON*
  - *Avionics switch ON, check fuel quantity sufficient for sortie*

- *Avionics & Master switch OFF*
- *Check Main wing spar for connection, bolts & nuts in position*
- *Safety belts undamaged*
- *Flaps handle down, check flaps for full deflection, and back to '0' position*
- *Emergency Parachute Release Handle safety pin 'IN'*

2. *Pre Flight External Checks.*

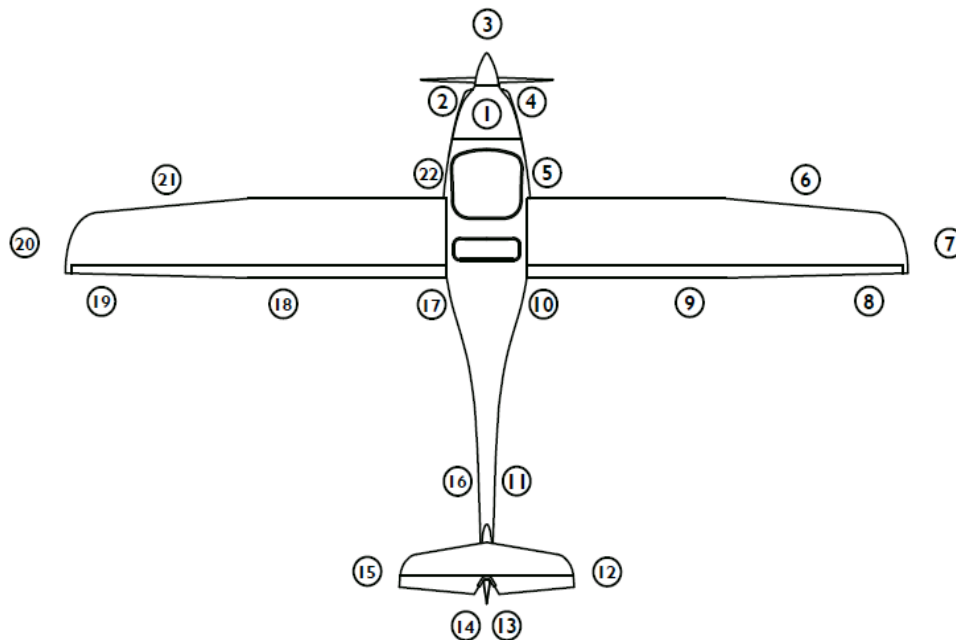

- |                             |                                |                               |
|-----------------------------|--------------------------------|-------------------------------|
| 1 Engine, engine cover      | 8 Right wing - trailing edge   | 15 Hor. tail surfaces (left)  |
| 2 Gascolator                | 9 Right wing - contnd          | 16 Fuselage, continued (left) |
| 3 Spinner, Nose wheel       | 10 Fuselage (RH side)          | 17 Fuselage (LH side)         |
| 4 Propeller                 | 11 Fuselage, continued (right) | 18 Left wing - contnd         |
| 5 Undercarriage, RH wheel   | 12 Hor. tail surfaces (right)  | 19 Left wing - trailing edge  |
| 6 Right wing - leading edge | 13 Vert. tail surfaces (right) | 20 Left wingtip, lights       |
| 7 Right wingtip, lights     | 14 Vert. tail surfaces (left)  | 21 Left wing - leading edge   |
|                             |                                | 22 Undercarriage, LH wheel    |

### Engine Cowling.

- *Fasteners and engine cowling screws in place, cowling undamaged.*
- *Spinner dome – No mechanical damage, bolts & nuts in place*
- *Propeller for any damage / cracks, clean, bolts & nuts secure*
- *Nose undercarriage for any mechanical damage, hydraulic line secure, no leaks*
- *Nose tyre for cuts, cracks and creep*
- *Engine cowling RH side, check coolant level minimum half way to top through panel, Exhaust pipes free of cracks*
- *Wing leading edge for surface condition, cleanliness, cracks, pitot tube firmly attached, no damage, no block*
- *Wing tip for surface condition of tip, Nav / strobe lights for condition, wings for play*
- *Wing trailing edge for any damage, Flaperon movement, vertical or horizontal play*
- *Undercarriage (starboard) for any mechanical damage, hydraulic pipes for condition / leaks, tyre for cuts, cracks and creep*
- *Parachute cover in position, no damage*
- *Tail boom free of damage / cracks*

- *Horizontal tail surface for cracks, hinges for play, central securing screw fastened and secure*
- *Elevator surface for smoothness, free movement up & down, no side to side play*
- *Vertical tail surface for cracks, hinges for play, rudder cable ends intact & in position*
- *Fuel tank cap secure*
- *Antenna firmly attached*
- *Undercarriage (port) for any mechanical damage, hydraulic pipes for condition / leaks, tyre for cuts, cracks and creep*
- *Wing trailing edge for any damage, Flaperon movement, vertical or horizontal play*
- *Wing tip for surface condition of tip, Nav / strobe lights for condition, wings for play*
- *Wing leading edge for surface condition, cleanliness, cracks*

3. *Entering Cockpit.* *To enter the cabin, first lift the door all the way to the bottom wing surface. The silver knob will grab and secure the glass door in position. Sit onto the cabin's edge and support body by placing both hands on to the cabin edge. Drag oneself into the seat, lifting only one leg over the stick for best position. Immediately after having sat into the seat, check rudder pedals position to suit size and needs by pulling the round black knob ahead of the stick on the floor. Position of pedals may also be adjusted during flight. To lower door, do not attempt to grab and pull door handle, but*

*gently pull the silver knob instead. To close door securely, rotate the handle so that it locks and verify that all three closing points are secured. Fasten seat belts according to size, with the help of ground crew.*

*4. Put on the headsets and adjust mic position.*

- Select Master Switch ON.*
- Avionics switch ON.*
- Check all instruments and EMS display ON*
- Select intercom switch ON, RT set ON, Check reading str 5*
- Obtain permission from ATC for start up.*
- Remove safety pin from Parachute Emergency Release Handle*

*5. Checks before Engine Start.*

- Check fuel quantity sufficient for duration of flight*
- Confirm Pitot cover removed*
- Confirm Parachute safety pin removed*
- Engage wheel brakes and apply parking brakes*
- Check fuel valve open, fuel CB IN, fuel pump on (by sound)*
- In case of cold start, select choke fully open by pulling choke lever fully back*

- *Select Avionics OFF and both magnetos ON*
- *Check area around and propeller area clear. Take clearance from ground crew for start*
- *Engage starter button till engine starts (not more than 10 seconds, in one go)*
- *Select Avionics switch ON*
- *Check oil pressure registering and within limits*
- *Set throttle to adjust RPM below 2500*
- *Select choke lever fully forward (Closed) while maintaining RPM*
- *Check Engine parameters normal.*

6. *Engine Warm Up.* *Engine is required to be warmed up, at not more than 2500 RPM, till such time working temperatures of oil is achieved. Engine warm up is to be avoided at idle RPM, as this causes spark plugs to turn dirty.*

- *Engine throttle to be set to 2500, till oil temperature reaches 50 deg Celsius*
- *Ensure engine nose pointing into wind*
- *Ensure engine temperature & pressure with operational limits*

7. Magneto Drop Check.

- *Indicate intention to ground crew. Check Parking Brakes ON, Control stick fully backward*
- *Check engine oil temperature 50 deg Celsius or above*
- *Slowly open throttle to set engine RPM 4000*
- *Select Left magneto switch off, note drop in RPM, call out drop, not more than 300*
- *Select Left magneto switch ON, check RPM regains to 4000*
- *Select Right magneto switch off, note drop in RPM, call out drop, not more than 300*
- *Select Right magneto switch ON, check RPM regains to 4000*
- *Check difference in drop on both sides not more than 115*
- *Open full throttle and check engine RPM between 5300 – 5500 and not more than 5800 on ground.*
- *Check engine parameters with operational limits*
- *Close throttle fully (fully back), note idle RPM*

8. Checks before Taxi.

- *Check and call out compass heading, ensure reading parking heading*
- *All flight instruments serviceable*
- *Altimeter set to QNH*
- *Engine parameters with operational limits, call out individually*
- *Wing tip Nav / strobe lights switch ON*
- *Take RT permission from ATC for taxi*
- *Check area around and taxi path clear*
- *Throttle idle and wave off chocks*
- *Cleared by ground crew, select Parking Brakes OFF*

9. Taxy Procedure. *Once cleared by ground crew and chocks removed, select Parking Brakes OFF. Open throttle to set engine RPM 1800 and release brakes. As aircraft starts moving forward, close throttle and apply brakes to check serviceability. Taxy at slow walking speed when in dispersal and at fast walking pace outside the dispersal. Adjust speed with RPM and brakes. Adjust direction with rudder pedals. Do not use brakes against power. In case of prolonged taxiing, check brake serviceability every 200 metres.*

10. *Approaching taxi holding point short of the runway, apply brakes gradually to stop aircraft, select parking brakes ON and ensure aircraft not moving forward. Carry out vital actions before take off.*

11. Vital Actions Berfore Take Off.

- *Check Parachute safety pin removed.*
- *Select flaps as required for take off (Flaps 1 or Flaps 2)*
- *Trimmer in neutral position*
- *Choke fully forward*
- *Fuel valve open, fuel quantity adequate*
- *Landing light ON*
- *Master / Avionics / Magneto switches ON*
- *Flight instruments serviceable. Altimeter set to airfield elevation, back to QNH, note correction*
- *Engine parameters callout  
Oil Pr / Oil Temp / CT 1 & 2 / EGT 1 & 2 / Fuel Qty (%)*
- *Check full and free movement of controls, no fowling or grinding noise*
- *Check Harness tight and door closed and locked. Confirm from copilot*
- *Check wind direction and speed*
- *Note time. Give RT call for line up.*

12. Line up Procedure. Once cleared to line up by the ATC, check baseleg, approach and runway clear. Release parking brakes, open throttle to 1800 RPM and move forward. Before entering runway, recheck approach and runway clear. Enter the runway at 90 deg to runway heading. Approaching the centre line, slowly turn with the help of rudder pedals, so as to roll out along the centre line, looking at the far end of the runway. Roll straight for a short distance to ensure nose wheel is straight before applying brakes.

13. Checks on Line Up.

- Throttle to idle, aircraft on brakes, aircraft not moving forward
- Check compass reading runway heading, note correction if any
- Take off path ahead and above clear
- Give RT call to ATC for take off

14. Take off Procedure. Once cleared for take off by the ATC, release brakes, open throttle slowly to full power. Check engine RPM 5300 – 5500. Engine Parameters within limits. As aircraft starts moving forward, maintain direction with rudder pedals. Check ASI registering. As aircraft accelerates, slowly bring control stick to 1/3<sup>rd</sup> back and lift nose wheel off the ground. Maintain direction with rudders. Speed approaching 40 – 43 Knots, gently pull back on stick to get airborne.

15. Checks after Take Off.

- Safely airborne, correct climbing attitude, wings level
- Accelerate at full power

- *Apply brakes momentarily to stop wheels rotating*
- *Height 150 ft, speed 50 knots, select / check flaps at Flaps 1 position*
- *Height 300 ft, speed 70 knots, select flaps to Flaps 0 position*
- *Reduce engine RPM to below 5300 or by 10 % (whichever is less)*
- *Landing light OFF*
- *Check engine parameters within limits*

16. *Climb & Cruise Procedure.* *In case of cross country flight or cruise flight, climb at 100 Knots speed to increase overall travelling speed. Reaching cruise altitude establish horizontal flight and set engine power to cruise setting (5300 RPM). Carry out checks of engine and flight parameters every 05 minutes.*

17. *Checks during Cruise.*

- *Height / speed / direction correct*
- *Engine parameters within operational limits. Call out Oil Pr / Oil Temp / CT 1 & CT 2 / EGT 1 & EGT 2 / Fuel quantity*

18. *Descent Procedure.* *Prior to descent, obtain RT permission from the ATC and confirm rejoin instructions. Once cleared to descent, orientate with respect to the destination airfield, select throttle to idle and as speed approaches  $V_{NO}$  or below, lower attitude to maintain speed below  $V_{NO}$ , while losing altitude.*

\* - *During descent, if throttle on idle setting, ensure throttle is opened slightly for short periods of time, to ensure spark plugs do not turn dirty.*

19. Rejoin, Circuit, Approach & Landing. *Dealt with as a separate chapter.*

20. Checks after Landing.

- *Clear off runway. Stop aircraft.*
- *Parking brakes ON. Aircraft not moving forward.*
- *Select Flaps to position '0'.*
- *Landing lights OFF.*
- *Note flight time*
- *Parking Brakes OFF. Taxi to dispersal*

21. Switch Off procedure.

- *Close throttle to idle. Allow engine to cool down for 01 minute*
- *Parking Brakes ON. Check aircraft not moving forward, give clearance to position chocks*
- *RT call*
- *Engine cool time over, select all green switches off*
- *Avionics OFF. Both magnetos OFF. Master switch OFF*
- *Fuel Pump CB OUT / Fuel shut off valve close*
- *Release parking Brakes*
- *Insert Parachute safety pin*
- *Exit aircraft and position pitot cover*

## CHAPTER V

### CIRCUIT APPROACH & LANDING

1. Normal circuit for Virus SW 80 aircraft shall be flown at 700 ft AGL at a speed of 70 – 75 Knots. RPM required for maintaining this speed and height on circuit will vary significantly with total weight of the aircraft (Occupants + fuel quantity) and airfield elevation. Hence, suggested settings need to be applied with due consideration to the All Up Weight of the aircraft, ambient temperature and airfield elevation. Prominent ground features may be used judiciously to maintain consistency in the circuit pattern.

2. Normal circuit is a procedure followed to ideally position the aircraft on final approach and execute a flawless safe landing. A circuit procedure has the following legs, that are followed sequentially.

(a) Take off leg. In the direction of take off. Starts at commencement of take off roll till reaching safe height to commence crosswind turn. Aircraft is in continuous climb during this phase.

(b) Crosswind leg. Perpendicular (90°) to the direction of take off, moving away from the runway. Starts at commencement of crosswind turn till commencement of turn on to downwind. Includes the duration when circuit height is attained and aircraft levels out.

(c) Downwind leg. Parallel to the runway and in opposite to direction of take off. Starts from the time aircraft rolls out parallel to runway in opposite direction till commencement of Base leg turn.

(d) Base leg. Perpendicular (90°) to take off / landing direction, flying towards the runway. Starts when aircraft rolls out 90° to direction of take off / landing till commencement of turn onto final approach.

(e) Final Approach. In direction of runway in use. Starts from top of final approach till aircraft comes to a stop on runway.

3. Take Off. After RT clearance from the ATC, perform a normal take off as mentioned in the procedure for take off. While carrying out checks after take off, after raising flaps to position '0', accelerate to 75 knots speed and continue climb. Approaching 500 feet AGL, check turning path to the left / right clear and commence a climbing turn, so as to roll out 90° to the runway heading, flying away from the runway.

4. Crosswind. Commence levelling out 50 feet before reaching 700 feet AGL. As speed tends to increase, reduce power to maintain speed 75 knots by selecting appropriate engine RPM (Approximately 4300 RPM). At appropriate ground position, commence a level turn to left / right so as to roll out on downwind.

5. Downwind. Recommended lateral displacement for downwind leg is 0.7 NM. This displacement provides a good margin of safety in case of engine failure, while providing optimum time to reach approach path under normal conditions. Once rolled out on downwind, check height, speed and direction correct and carry out downwind checks (Vital Actions Downwind).

- Check displacement correct / aircraft flying parallel to runway
- Height 700 feet AGL / Speed 70 – 75 knots
- Engine parameters within limits. Call out –  
Oil Pr / Oil Temp / CT 1 & CT 2 / EGT 1 & EGT 2 / Fuel quantity
- Landing lights ON. RT Call

6. *Abeam live dumbbell, reduce engine power to idle RPM. Maintain attitude and height to reduce speed to 70 knots. Trim aircraft and do not descend. As speed reduces below 70 knots, select flaps to position '1' (Flaps 15°). Aim to achieve speed 60 Knots before turning on to Base leg. When touchdown point approaches between 30° and 45° (between 0800 to 0730 clock code position (for left hand circuit) / 0400 to 0500 clock code position (for right hand circuit)) commence turn onto base leg.*

7. *Base Leg.* *Roll out 90° to the runway heading, flying towards the runway. Commence descent to maintain speed 60 knots and slowly wash off speed and height, aiming to reach end of base leg with height 500 feet and speed 55 knots. When the threshold / touch down point is 0930 / 0230 clock code position commence turn on to finals. Maintain speed 55 knots.*

8. *Final Approach.*

*Checks on Finals.*

- *Alignment correct*
- *Throttle to idle*
- *Perspective correct*
- *Speed below 55 knots, select flaps to position '2' (Flaps 25°)*
- *RT call. Maintain speed 50 knots*

9. *Use throttle to control descent and attitude to control speed. Approach is to be maintained in a manner that the aircraft is physically headed towards the threshold / touchdown point. Approaching close to ground, slowly raise attitude aiming to land the aircraft in a manner that main wheels touch the ground first. Touch down, under normal wind conditions will occur at 40 knots. Allow nose wheel to touch down only after speed has been reduced to below 27 knots. Maintain rudder pedals central when lowering nose wheel*

to ground. Once on ground, apply braking action, holding the control stick fully back. Steer the aircraft using rudder pedals only.

## **CIRCUIT PATTERN SCHEME**

### **CROSSWIND LEG**

50 ft before reaching 700 ft start  
Establishing level flight while reducing  
Power to 4300-4500 RPM  
Sp 76 kts

### **TAKE OFF LEG**

Release Brakes  
Full power  
RPM > 5000  
Unstick at 40 Kts IAS  
Establish climb while  
accelerating  
Sp 50 kts Ht 150' Flaps 1  
Sp 70 kts Ht 300' Flaps 0  
Reduce RPM below 5300  
Sp 76 kts  
Ht 500' turn path  
clear, commence  
turn to cross

700 ft AGL  
Ht / Sp / Dir / Displacement  
Level Flight

### **DOWNWIND CHECKS**

Ht 700' / Sp 76 kts / Dir  
Engine parameters  
Landing lights  
RT call

Throttle to idle  
Maintain level  
Reduce Sp to 70 Kts  
Establish descent thereafter  
Select Flaps 1

Descending turn to base

### **FINAL**

Sp below 55 Kts  
Flaps 2  
Approach Sp 50 Kts

### **BASELEG**

Sp not below 55 Kts      Reduce Sp 60 Kts

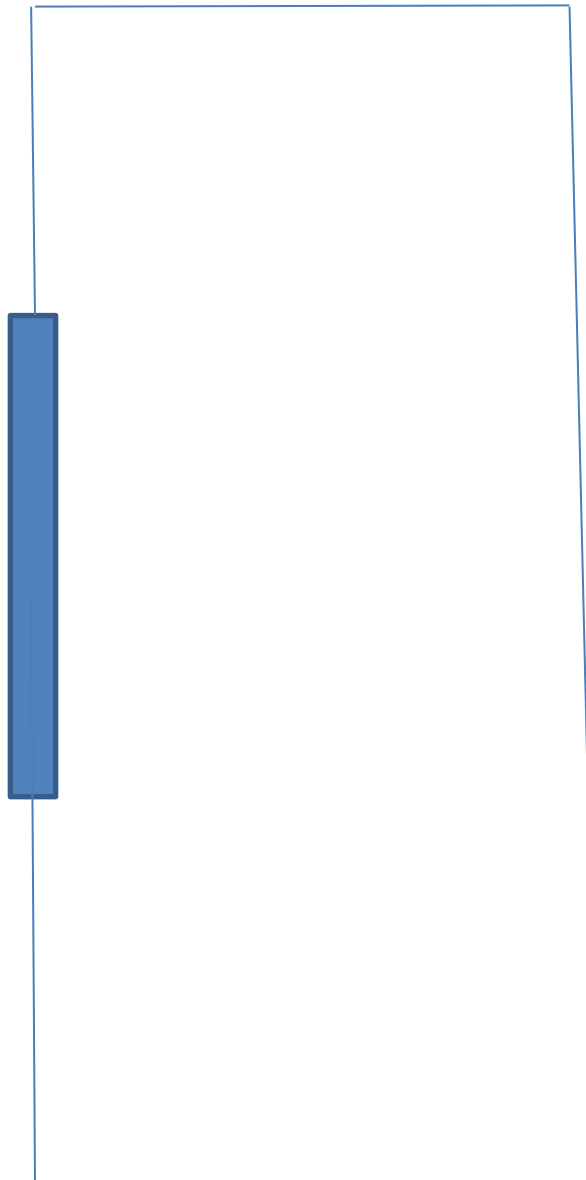

# CHAPTER VI

## STALL & SPIN RECOVERY

1. *Virus SW 80 Garud aircraft is easy to recover from stall or spin manoeuvres.*

### Stall.

2. General. *Stall speeds of the aircraft in different configurations are as follows.*

- (a) *Clean - 43 Kts*
- (b) *Flaps 15° - 38 Kts*
- (c) *Flaps 25° - 34 Kts*

Note. *Minimum height to commence the maneuver of stall is 1500 ft AGL. Height loss in recovery is around 200 ft.*

3. Internal checks before Stall.

- *Height sufficient for recovery (Minimum 1500 ft AGL)*
- *Airframe configuration (Clean / Flaps 15° / Flaps 25°)*
- *Engine Parameters within limits*
- *Location, sufficient sector length available*

4. External Checks before stall.

- *Check within local flying area in allotted sector*
- *Not over populated or prohibited area*
- *Away from clouds & large expanse of water*
- *Not likely to enter clouds, especially during recovery*
- *Point of reference selected for orientation*

5. Stall Recovery Procedure.

- Move control stick forward to reduce angle of attack. Horizon 1/3<sup>rd</sup> from top of canopy for clean stall and horizon on top of canopy for stall with flaps
- Smoothly open full power (throttle lever to fully forward position)
- Speed approaching 50 Kts, resume horizontal flight. Do not stress the aircraft when pulling out
- Care must be taken not to exceed 70 Kts / 55 Kts during recovery from stall with Flaps 15° / Flaps 25°

6. Safety checks after recovery from stall.

- Engine parameters within limits
- Orientate with point of reference
- RT call for 'Operations Normal'

Spin.

7. Intentional entry into spin on Virus SW 80 aircraft is prohibited.

The aircraft is designed in a manner that it is difficult to be flown into a spin, and even so only at aft Centre of Gravity positions and full rudder deflections. Minimum height to commence a one turn spin is 2500 ft AGL.

8. Internal checks before Spin.

- Height sufficient for recovery (Minimum 2500 ft AGL)
- Airframe configuration (Clean)
- Engine Parameters within limits
- Location, sufficient sector length available

9. External Checks before Spin.

- Check within local flying area in allotted sector

- *Not over populated or prohibited area*
- *Away from clouds & large expanse of water*
- *Not likely to enter clouds, especially during recovery*
- *Point of reference selected for orientation*

10. Entry. *Proceed as for a stall. Before getting throttle to idle, pick up a point of reference and orientation. At 45 Kts, start applying rudder and keep getting the stick back. As aircraft enters spin, apply full in-spin rudder and stick fully back. Count number of turns and take recovery action.*

11. Spin Recovery. *Once spinning, intentionally or otherwise, effect recovery as follows.*

- *Set throttle to idle (lever fully back, in case of unintentional spin)*
- *Apply full rudder in direction opposite to spin*
- *Move stick centrally and progressively forward*
- *As aircraft stops spinning, stop stick movement and centralise rudders*
- *Check speed 50 Kts and slowly pull up to regain horizontal flight, opening throttle simultaneously. Do not stress the aircraft during pull out*

Note. - *Aircraft tends to re-establish normal flight by itself usually after having spun for just 90° - 180°*

- ***Keep control stick centered along lateral axis. No application of ailerons during recovery phase. Do not attempt to stop spin using ailerons, instead of rudder***

- ***After aircraft stops spinning, recovery from dive must be effected using gentle stick movements, rather than overstressing the aircraft***

- ***VNE must not be exceeded during the maneuver***

## CHAPTER VII

### EMERGENCY PROCEDURES

#### ENGINE FAILURE

1. Engine Failure during Take Off.

- Maintain correct air speed 55 Kts
- If sufficient runway length available ahead, land aircraft
- Avoid obstacles, if any, in your way
- Select fuel shut off valve OFF
- Select Master switch OFF

Note. Do not change course or make turns unless necessary. After having landed safely, ensure protection of aircraft and vacate runway, at the earliest, to keep runway clear for other traffic.

2. Rough engine operation or engine failure in flight.

- Ensure correct air speed 64 Kts
- Start analyzing terrain below
- Choose most appropriate site for landing out

Provided engine failed aloft, react as follows.

- Ensure Master switch is in ON position
- Magneto switches both set to ON
- Fuel valve open
- Attempt to restart the engine
- If unsuccessful, begin with landing out procedure immediately

### Emergency Landing / Landing Off Airport.

- Fuel valve OFF
- Master switch OFF
- Approach and land with extreme caution, maintain normal speed
- After having landed, leave the aircraft immediately

### ENGINE FIRE

#### 3. Engine Fire on Ground.

- Shut fuel valve OFF
- Come to full stop, engage starter and set throttle to full power
- Disconnect battery from the circuit (pull battery disconnection ring on switch column)
- Master switch OFF immediately after engine has stopped
- Abandon the aircraft and start the fire extinguisher

Note. After fire has been extinguished DO NOT attempt to restart the engine.

#### Engine Fire in Flight.

- Shut fuel valve OFF and set magnetos OFF
- Set full power (Throttle lever fully forward)
- Keep avionics ON and Master ON as required, on approach set both OFF
- Perform side slip / crab maneuver in direction opposite of fire
- Perform emergency landing out procedures

### Smoke in Cockpit.

- Avionics OFF
- Disconnect the battery from the circuit
- Land as soon as possible

Note. In case of trouble breathing or visibility out of the cockpit has degraded severely due to smoke, open the cabin door and leave it hanging freely. Flying with door open, do not, under any circumstances exceed 60 Kts.

### 4. Carburetor Icing.

- Indications. Rough engine noises and gradual loss of power
- May occur even at temperatures as high as + 10° C, provided air is highly humid
- Descend immediately to warmer and / or less humid air
- In case of complete loss of power, perform emergency landing out procedure

### 5. Electrical System Failure.

- Engine will continue to function due to onboard alternator and battery
- In case of battery failure, engine will continue to function, but restart will not be possible
- In case of alternator failure, battery will support all onboard avionics
- In event of double power failure (both alternator and battery fail) use GPS Instruments Page instruments and land normally

Note. In case of alternator failure, switch off unessential loads like Nav / Strobe lights, Landing lights to reduce power consumption.

6. Flutter.

- Defined as oscillation of control surfaces. Caused by abrupt control deflections at speeds close to or in excess of VNE.

- Indications. Ailerons , elevators or even the whole aircraft starts to vibrate violently

- Increase angle of attack (pull stick back) and reduce throttle immediately to reduce speed

- Increase load (damping) on structure

Note. Fluttering of control surfaces may cause permanent structural damage and / or inability to control the aircraft. After landing, aircraft must undergo series of checks to verify air worthiness.

7. Exceeding VNE.

- Reduce airspeed slowly

- Continue flying using gentle control deflections

- Land safely as soon as possible

- Have aircraft verified for air worthiness

8. Ditching.

- If forced to land on water body, use same emergency procedure as for emergency landing / landing out

- Make sure to open both doors fully before hitting water

- Disconnect the battery by pulling battery disconnection ring

- Touch water with the slowest possible speed, possibly from a high flare situation

9. Icing / Pneumatic Instrument Failure.

- Turn back or change altitude to exit icing conditions
- Maintain VFR flight
- Set cabin heating ON
- Look out for signs of icing on Pitot tube
- In case of pneumatic instruments failure, use GPS information for reference
- Plan to land at the nearest airport
- Manoeuvre the aircraft gently and keep flaps at Flaps '0' position

10. Electric Fuel Pump Failure.

- Indication. Either through engine switching off or zero fuel pressure indication. In case of partial fuel pump failure, fuel pressure will be indicated low.

- Attempt to reduce power to increase fuel pressure to achieve more reliable engine operation

Note. For normal flight operation, mechanical fuel pump provides adequate fuel pressure. Electrical fuel pump is a safety option to suppress eventual fuel vapour.